

- Hot-swappable redundant power units
- Remote management via CLI (SSH2, Telnet), SNMP, web
- Compliance with G.988, G.984.x and TR-156 standards
- Ability to provide cable TV together with data transmission
- Optimal solution for a small village or apartment building



LTP-8N



LTP-16N

OLTs are designed to provide broadband access over Passive Optical Network (PON).

GPON interfaces are used for connection of the optical distribution network (PON). Up to 128 subscriber optical terminals can be connected to each interface via a single fiber. Access to the carrier's transport network is provided via 10 Gigabit uplink interfaces.

OLT LTP allows carriers to build scalable, fault-tolerant 'last mile' networks to ensure the highest safety standards. OLT manages subscriber devices, traffic switching, and connection to the transport network.

Broadband subscriber access using the FTTH technology is the highest quality Triple Play service delivery option, as it provides high data transmission rates over long distances. The main advantage of PON technology is the absence of electrically powered active nodes within the section from OLT to ONT, which significantly reduces the network operating cost. Furthermore, PON technology saves on cabling infrastructure by reducing the total length of the optical fiber, since only one fiber for a single group of subscribers is used within the section from the central node to the splitter.

OLTs support 2 hot-swappable redundant power units.

Interfaces configuration

	LTP-8N	LTP-16N
10GE (SFP+)/1GE (SFP)	4	8
2.5/1.25 Gbps GPON	8	16
10/100/1000BASE-T (OOB)		1
Console port RS-232 (RJ-45)		1
USB 2.0		1
Maximum number of ONTs	1024	2048

Features and capabilities

Port modes

- 1/10 Gbps duplex mode for SFP+/SFP optical ports

SFP PON parameters¹

- Transmission medium: SMF-9/125 optical fiber cable, G.652
- Splitting ratio up to 1:128
- Support for RSSI (Received Signal Strength Indication)

Class B+

- Compliance with ITU-T G.984.2, FSAN Class B+, SFF-8472
- Maximum link distance: 20 km
- Transmitter: 1,490 nm DFB Laser
 - Data rate: 2.488 Mbps
 - Average output power: +1.5..+5 dBm
 - Spectral line width: -20 dB 1.0 nm
- Receiver: 1,310 nm APD/TIA
 - Data rate: 1.244 Mbps
 - Receiver sensitivity: -28 dBm
 - Receiver optical overload: -8 dBm

Class C++

- Compliance with ITU-T G.984.2, FSAN Class C++, SFF-8472
- Maximum link distance: 40 km
- Transmitter: 1,490 nm DFB Laser
 - Data rate: 2.488 Mbps
 - Average output power: +7..+10 dBm
 - Spectral line width: -20 dB 1.0 nm
- Receiver: 1,310 nm APD/TIA
 - Data rate: 1.244 Mbps
 - Receiver sensitivity: -32 dBm
 - Receiver optical overload: -12 dBm
 - Receiver burst mode dynamic range: 20 dB

Switch

- Switch performance: 120 Gbps
- MAC table: 64K entries
- Support for up to 4K VLAN (in compliance with 802.1Q)

Standards

- ITU-T G.988 GPON
- ITU-T G.984x GPON
- ITU-T G.8032/Y.1344 Ethernet ring protection switching²
- IEEE 802.3i 10BASE-T Ethernet
- IEEE 802.3u 100BASE-T Fast Ethernet
- IEEE 802.3ab 1000BASE-T Gigabit Ethernet
- IEEE 802.3z Fiber Gigabit Ethernet
- ANSI/IEEE 802.3 NWay auto-negotiation
- IEEE 802.3x Full Duplex and flow control²
- IEEE 802.3ad Link aggregation
- IEEE 802.1p Protocol for Traffic Prioritization
- IEEE 802.1Q Virtual LANs
- IEEE 802.1ad Provider Bridges (QinQ)
- IEEE 802.3ac VLAN tagging
- IEEE 802.1d MAC bridges
- IEEE 802.1w Rapid Reconfiguration of Spanning Tree²
- IEEE 802.1s Multiple Spanning Trees²

¹Parameter is defined when ordering.

²Not implemented in current version.

³For LTP-8(16)N rev.B hardware revision 1v3 and higher, in conjunction with PM160-220/12 rev.D power supply modules and higher.

Additional features

- VLAN mirroring, port mirroring
- MAC table: 64K per switch, 8K per port
- MAC address limiting
- STP, RSTP, MSTP²
- ERPSv2²
- QoS: 802.1p, DSCP², WFQ
- Port isolation, port isolation within a single VLAN
- Unicast/multicast/broadcast traffic shaping
- ACL IPv4
- QinQ in compliance with IEEE 802.1ad
- Up to 1024 multicast groups
- IGMP Fast Leave
- IGMP Proxy
- IGMP Snooping
- IGMP Querier
- DHCPv4 Snooping
- IP Source guard
- DHCPv4 Relay Agent (Option 82)
- PPPoE Intermediate agent
- LLDP (802.1ab)
- Storm Control
- Policy²
- Utilization by ONT services
- OMCI Bridge
- OMCI RG
- Hardware support for Dying Gasp³

Management and monitoring

- RADIUS, TACACS+
- CLI (SSH2, Telnet), SNMP, web
- Access restriction: by password, by IP address, by privilege level
- Multiple management interfaces

Physical specifications and ambient parameters

	LTP-8N	LTP-16N
Power supply ¹	90–264 V AC, 50 Hz; 36–72 V DC	
Average power consumption	40 W	55 W
Operating temperature	from -20 to +60 °C	
Operating storage temperature	from -50 to +70 °C	
Relative humidity	up to 80 %	
Dimensions with power supply unit installed (W × H × D)	430 × 44 × 317 mm, 19", 1U	
Weight	4.4 kg	4.5 kg

Use case

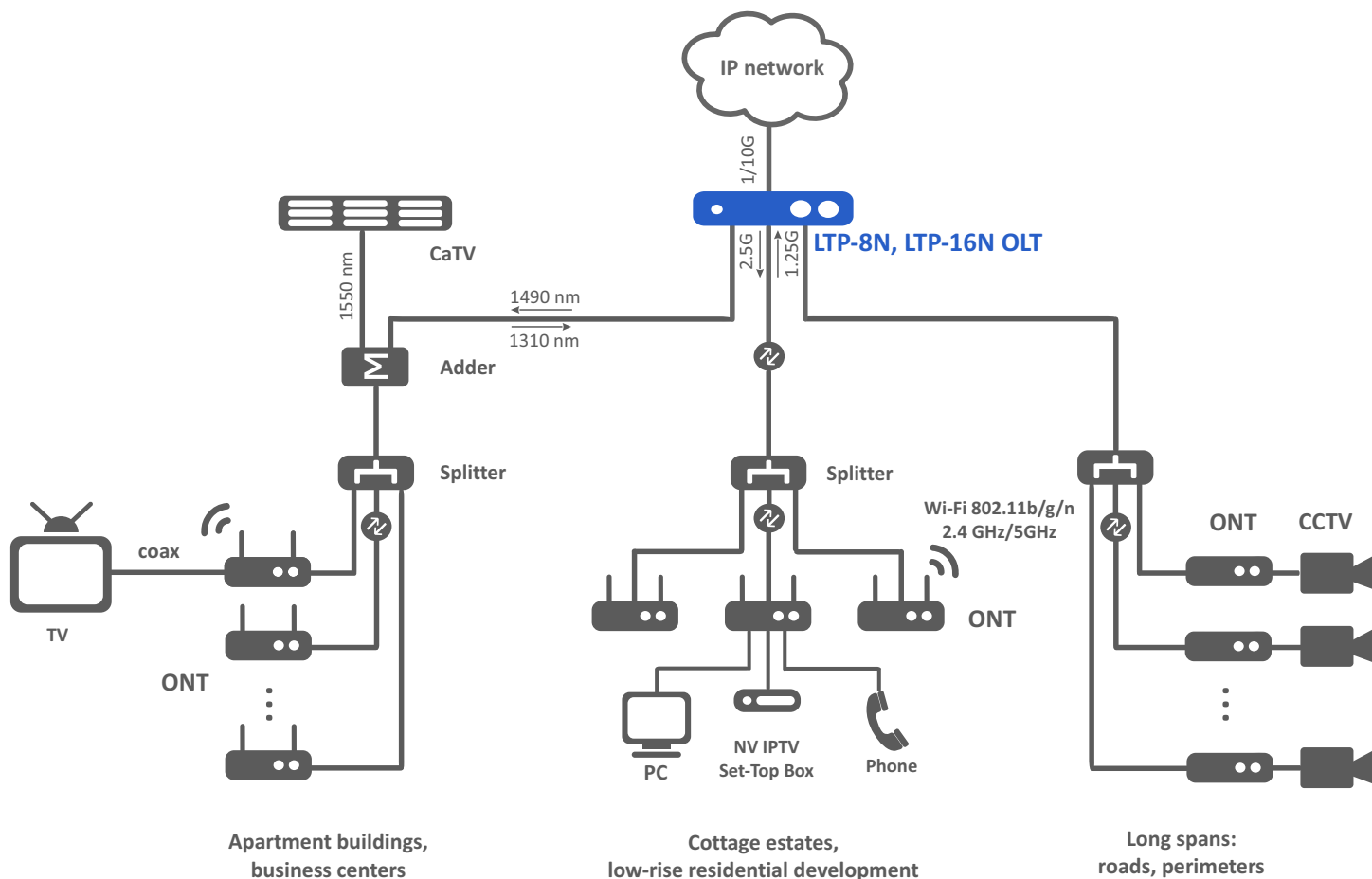

¹Parameter is defined when ordering.

Ordering information

Name	Description
LTP-8N OLT	LTP-8N OLT, 8 ports of SFP-GPON, 4 ports of 10GE (SFP+)/1GE (SFP), RSSI
LTP-16N OLT	LTP-16N OLT, 16 ports of SFP-GPON, 8 ports of 10GE (SFP+)/1GE (SFP), RSSI
Related products	
PM100-48/12	Power module PM100-48/12, 36–72 V DC, 100 W
PM160-220/12	Power module PM160-220/12, 90–264 V AC, 160 W

Contact us

About Eltex



+7 (383) 274 10 01
+7 (383) 274 48 48



eltex@eltex.ru



eltex-co.com

Eltex Enterprise is a leading Russian developer and manufacturer of communication equipment with 30 years of history. Complete solutions and their seamless integrability into the Customer's infrastructure are the priority growth areas of the company.